

FUA SERIES

Angular Food Grippers | Features and Benefits | How To Order

Features:

- Designed for direct product contact in the food zone, according to the food industry standard (EN 1672-2)
- All parts are corrosion resistant, non-toxic, non-contaminating, non-porous, non-absorbent and non-reactive
- Stainless steel design resists chemical cleaning procedures
- Electro-polished exterior with no recessed or inaccessible zones prevents retention of contaminants and simplifies cleaning
- Sealed motion components (IP69K design) for high-pressure and high-temperature daily cleanings
- Any metal/metal contact protected by gasket to obtain a leakproof assembly against bacteria
- Angular gripper design for easier radial sealing of jaws
- Optional safety springs for external gripping, in case of air supply failure, in single acting or spring assist mode
- No external fasteners to avoid any foreign matter in food
- Contains special lubricants suitable for food industry
- Long maintenance-free service life



(USB key shown for scale)

Applications:

- Food zone and splash zone handling of product
- Non-food zone applications
- Other applications requiring a sealed and corrosion resistant gripper

How To Order

Base Model
FUA-63M

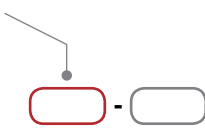

Spring	Description
"Blank"	None
C	Spring Closed

Angular Food Grippers | Dimensions and Technical Specifications

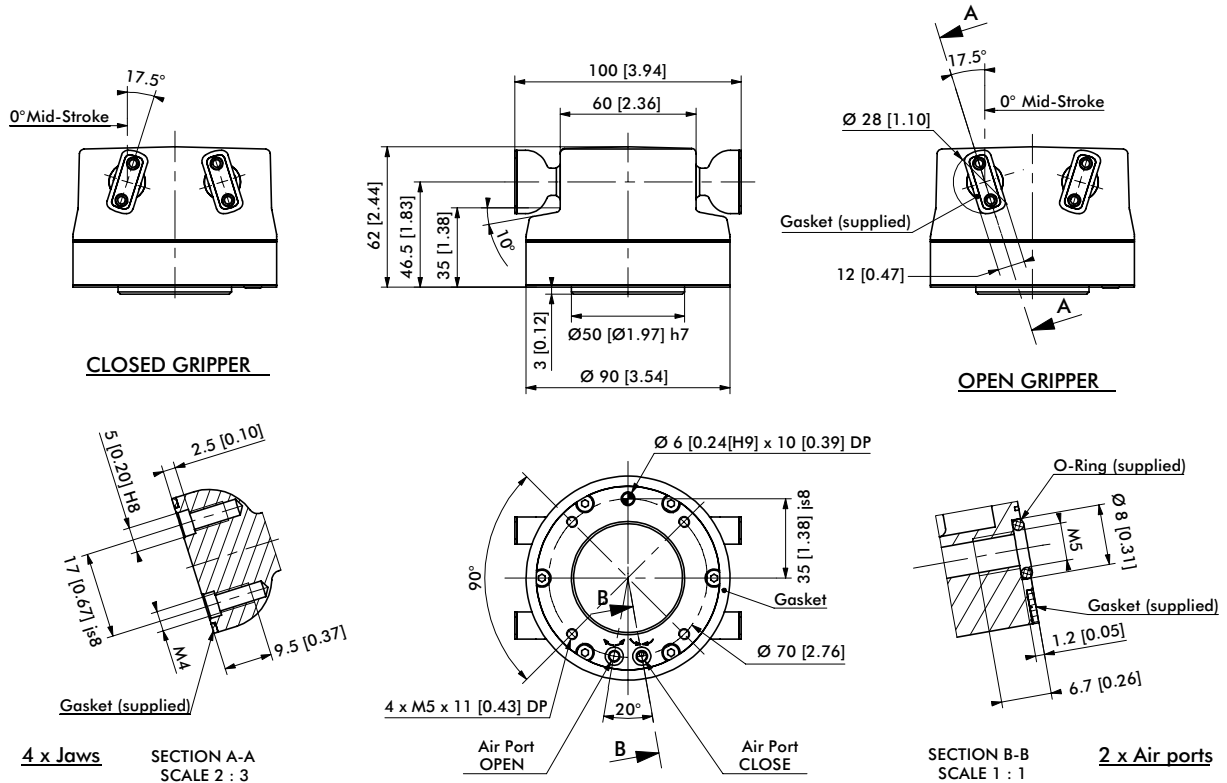

Specifications	Units	FUA-63M
Torque, Jaws @ 0° (mid-stroke)		
@ 6 bar [87 psi], w/spring	Nm [in-lbs]	32 [283]
@ 0 bar [0 psi], w/spring	Nm [in-lbs]	9 [80]
Total Stroke		70°
Weight (Stainless Steel)	kg [lbs]	1.7 [3.75]
Weight (Polymer)	kg [lbs]	0.8 [1.76]
Pressure Range without springs	bar [psi]	2-7 [30-100]
Pressure Range with springs	bar [psi]	3.5-7 [50-100]
Ingress Protection Class (IP)		IP69K
Displacement	cm ³ [in ³]	54 [3.30]
Temperature Range	°C [°F]	-15°~80° [5°~175°]